

# FOOD GRADE APPROVED

## ATMODOOR®



### SERIES 4700

## SUPER "TUFF" RIGID INSULATED IMPACT DOOR

Designed for door openings up to 10'W x 10'H, Series 4700 Super "TUFF" Rigid Insulated Impact Door withstands a wide variety of traffic while providing unmatched hinge protection in wash down areas. The heavy-duty cam type hinge hardware is fully enclosed within a one-piece 1/8" thick metal profile. The robust 1-3/4" thick panels are strong enough to withstand forklift traffic yet light weight enough for pedestrian traffic. Large thermopane windows ensure maximum user safety. Available in a large selection of colours, 4700 doors are ideal for supermarkets, retail stores, processing plants, warehouses and refrigerated applications. Foam injected insulation and full gasketing provide excellent environmental control and reduce energy costs.

# SUPER SEAL

Tel: 905.850.2929 Tel: 1.800.337.3239  
Fax: 905.850.2922 Fax: 905.850.4440

[www.supersealmfg.com](http://www.supersealmfg.com)

SuperSeal Mfg. Ltd.  
670 Rowntree Dairy Rd.,  
Woodbridge, Ontario, Canada L4L 5T8

# SPECIFICATIONS



## Series 4700 Product Details:

- The Series 4700 will suit door openings up to and including 10' wide x 10' high. Extra height available with Double Dutch option.
- Fully enclosed, self-aligning hinge system with spring tension.
- Series 4700 is FOOD GRADE APPROVED.
- Textured ABS panels resist dents, scuffs and abrasions. Injected foam insulation adds rigidity and strength.
- All hardware corrosion resistant.
- Complete stainless steel option available.
- Recommended door jamb: Steel frame mounted to a solid foundation, 4"W x 1/4" thick (Model 4701) or 6"W x 1/4" thick (Model 4702).
- Custom sizes available. Face cover colours may be different on each side to suit application.

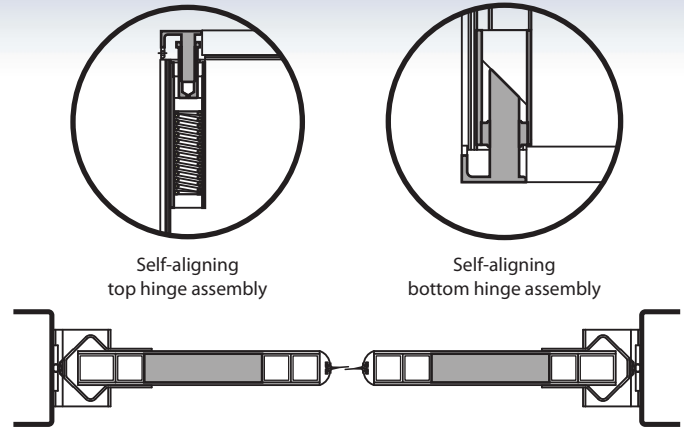

## Traffic Types:



## Specifications:

**Model 4701** is a medium-duty impact door with 1-1/2" thick tubular PVC internal framing. Mounting hardware is suited for minimum 4" wide jambs. **Model 4702** is a heavy-duty impact traffic door with 1-1/4" and 1-1/2" square steel tubular internal framing. Mounting hardware is suited for minimum 6" wide jambs. **Models 4701 & 4702** door bodies shall be 1-3/4" thick, double acting and shock absorbent. Internal core shall be insulated with high-density injected foam. Outside skin shall be 1/8" thick ABS, chemically bonded to both sides of panel frame. All panel edges shall be finished with replaceable rubber gasket edge set in black PVC extrusion. Jamb edge of panels shall be clamped in a metal profile with 1/8" thick walls and secured with corrosion resistant hardware. Each panel shall have a clear, true thermopane window with a black PVC molding. Hinge assemblies shall be self-aligning with compression spring at top and V-Cam pin at bottom. Compression spring assembly shall be totally enclosed within jamb-edge profile. Double acting hinges shall swing 90° in both directions.

## Options:

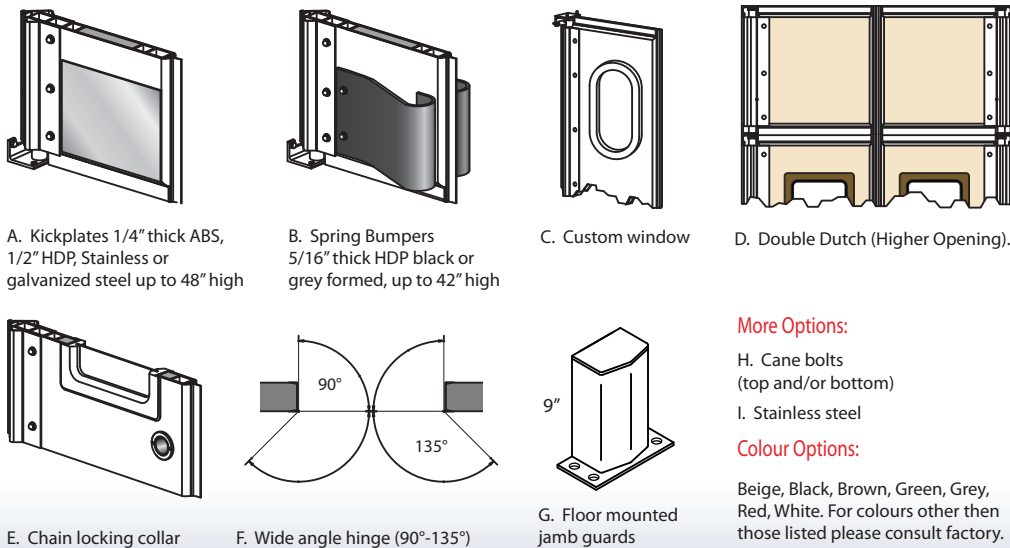

A. Kickplates 1/4" thick ABS, 1/2" HDP, Stainless or galvanized steel up to 48" high

B. Spring Bumpers 5/16" thick HDP black or grey formed, up to 42" high

C. Custom window

D. Double Dutch (Higher Opening).

E. Chain locking collar

F. Wide angle hinge (90°-135°)

G. Floor mounted jamb guards

### More Options:

- H. Cane bolts (top and/or bottom)
- I. Stainless steel

### Colour Options:

Beige, Black, Brown, Green, Grey, Red, White. For colours other than those listed please consult factory.

## Applications:

- Double Acting
- Industrial (4702)
- Manufacturing
- Warehousing
- Supermarket
- Food Processing
- Wash down Applications
- Institutional
- Stock Room
- Prep Room
- Retail

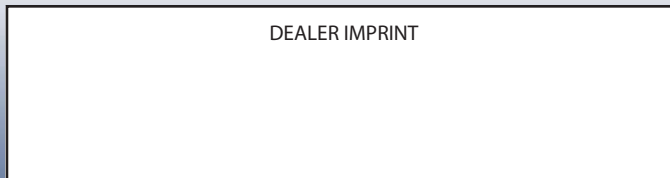

\*\* All Super Seal products are subject to design modifications without notice. Product may be shown with options.E.&O.E